

APPLICATION NOTE

Micro Vibration Sensor
MVS1006.01 / MVS0608.02
MVS0409.02

Index

1. Sensor evaluation.....	3
2. Basic circuit.....	4
2.1 General description	4
2.2 Circuit.....	4
3. Filter Circuit.....	5
3.1 General description	5
3.2 Circuit.....	5
4. Not recommended circuit.....	7
4.1 General description	7
4.2 Circuit.....	7
5. Measuring Note.....	7
6. Defined rest state output	8
6.1 General description	8
6.2 Circuit.....	8
7. Delay circuit.....	10
7.1 General description	10
7.2 Circuit.....	10
8. Digital filter	12
8.1 General description	12
8.2 Circuit.....	12
8.3 Schematic	13
8.4 Implementation.....	13
9. MOSFET Circuit	15
9.1 General description	15
9.2 Circuit.....	15
10. Important Notice	17

1. Sensor evaluation

Both versions of the micro vibration sensor (unidirectional MVS1006.01 and omnidirectional MVS0608.02/MVS0409.02) are **not necessarily closed** when **at rest**. Only in 70% - 99% of time they will be closed when at rest as shown in Figure 1. The circuit and/or the software of the electronic device should evaluate state changes from open to closed or closed to open instead of steady states open or closed.

If the sensor is at one DC-level (e.g. high), a slight vibration may cause the sensor signal to toggle. This fake motion cannot be filtered out by the “Small filter circuit” and has to be handled by the μC software. If a hardware solution is needed for this situation the DC part of the signal has to be filtered out first by a high pass filter to get a defined rest state output.

Figure 1: Micro vibration sensor, contacts not necessarily closed at rest (idealized plot)

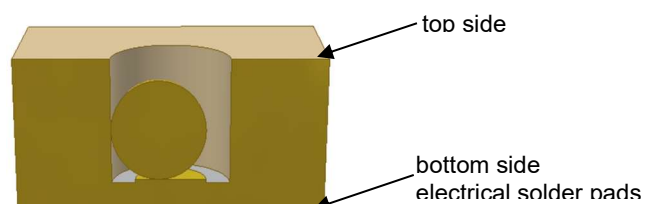

Figure 2: Micro vibration sensor, micro sphere at rest, contacts not necessarily closed

The unidirectional sensor version MVS1006.01 is open at rest, when mounted in upside down position, so that the micro sphere is on the top side of the sensor, which has no contact pad.

2. Basic circuit

2.1 General description

The most simple circuit with a minimum of component requirement.

R1 should be chosen to limit the maximum current through the sensor to a maximum value of 2mA.

2.2 Circuit

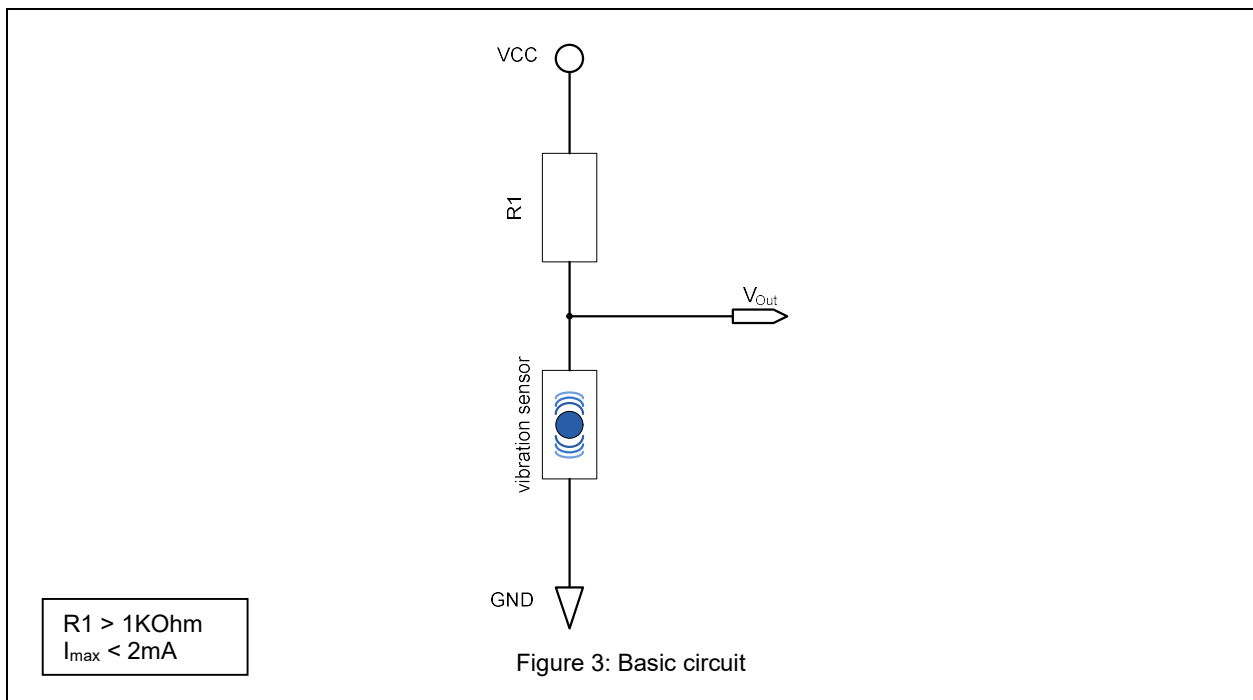

3. Filter Circuit

3.1 General description

In order to reduce the sensitivity of the sensor, a small capacitor can be added to the evaluation circuit presented in Figure 4. Additionally to the capacitor C1 a resistor R2 is applied, which limits the current through the sensor when the capacitor impedance is low.

For low power applications high values of R1 and R2 can be used to limit the current. If high resistor values are used, the circuit impedance must be considered. For the resistive voltage divider a good value of R1 is 5.1M, and R2 can be between 100k and 1M, depending on the desired output voltage swing.

C1 can be varied on a range of 10pF to 1nF for different filter options. A larger C1 value e.g. 100nF will turn the peaks of the output into an analog average value shown in Figure 5.

3.2 Circuit

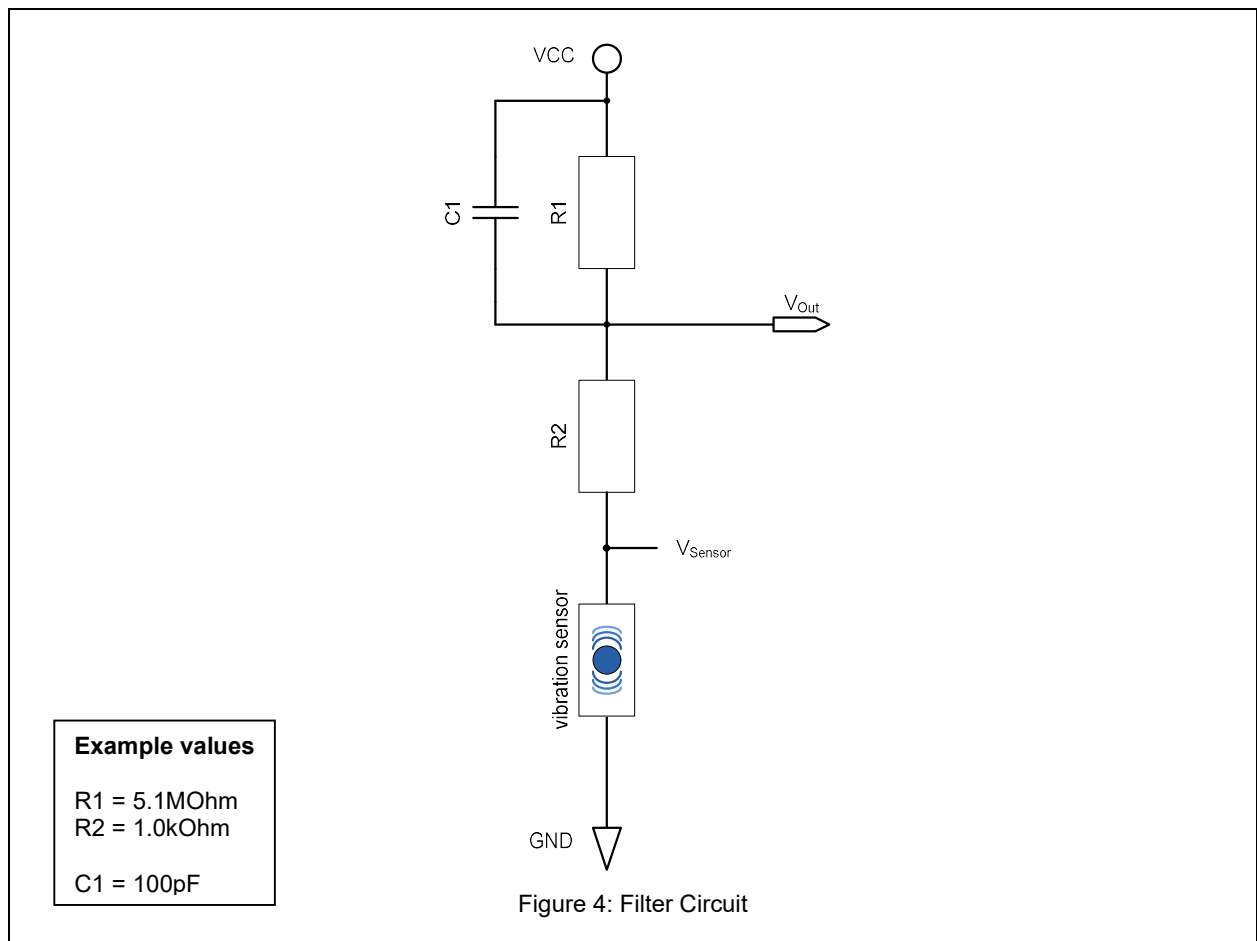

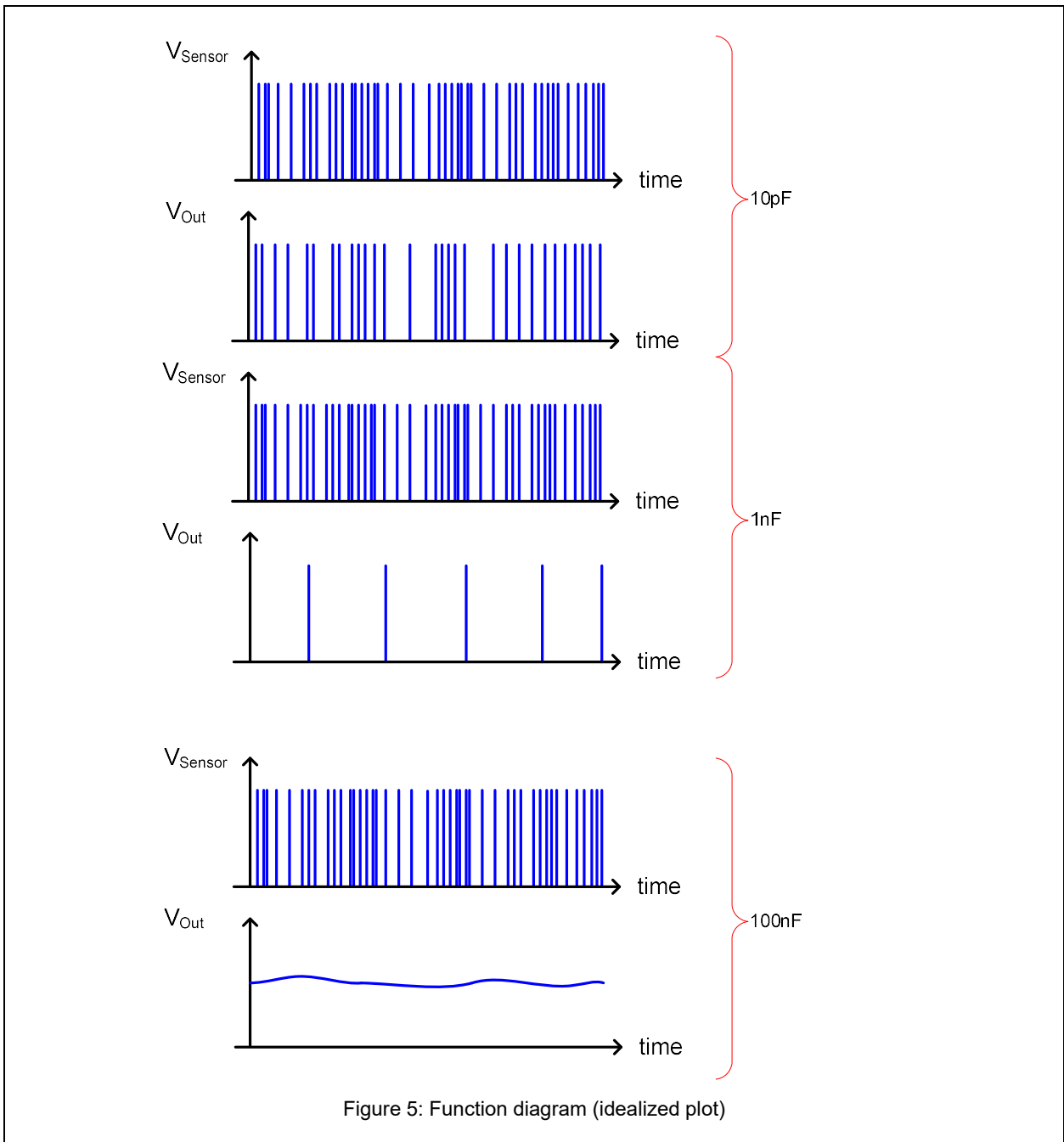

4. Not recommended circuit

4.1 General description

It's not recommended to connect a capacity from any supply directly to the sensor. When the sensing mechanism opens and closes, a large inrush current will occur. It will potentially damage the contacts and reduce life of the Sensor.

4.2 Circuit

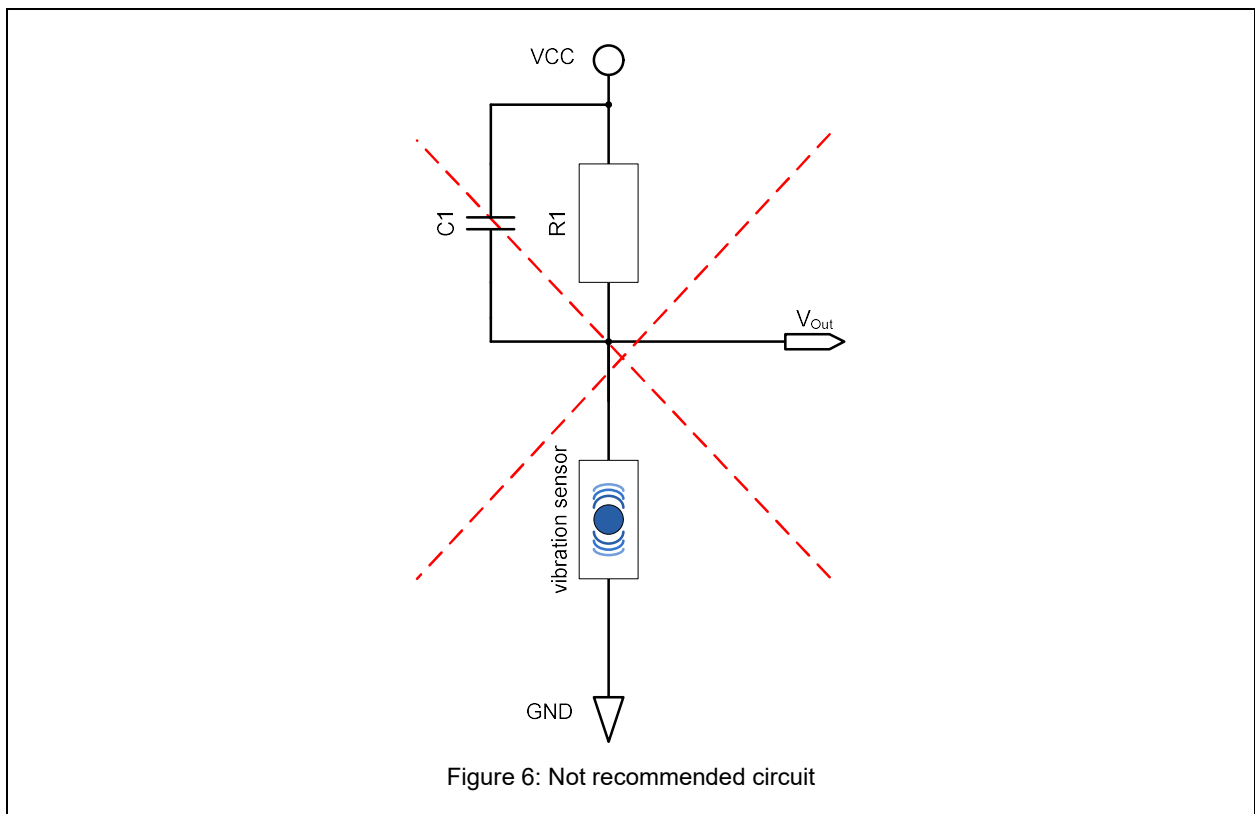

Figure 6: Not recommended circuit

5. Measuring Note

When measuring with an oscilloscope, it is recommended to use the 10x probe for circuit debugging. If 1x probe is used, the series resistance will cause a large voltage drop.

6. Defined rest state output

6.1 General description

Both versions of the micro vibration sensor (unidirectional MVS1006.01 and omnidirectional MVS0608.02/MVS0409.02) are not necessarily closed when at rest. Only in 70% - 99% of time they will be closed when at rest.

This circuit can be used, if the output signal needs to be **low** when the sensor is at rest (see Figure 8).

For low power applications high values of R1 and R2 can be used to further limit the current, however the circuit impedance must be considered. Depending on the desired output voltage swing resistor values of 5.1M R1 and 1.0k R2 can be used.

The capacitive voltage divider determines the filter characteristics. C2 should be $\geq 5C1$. A value of 100pF for C1 keeps the high sensitivity of the sensor. A large C1 value e.g. 100nF will turn the peaks of the output into an analog average value.

6.2 Circuit

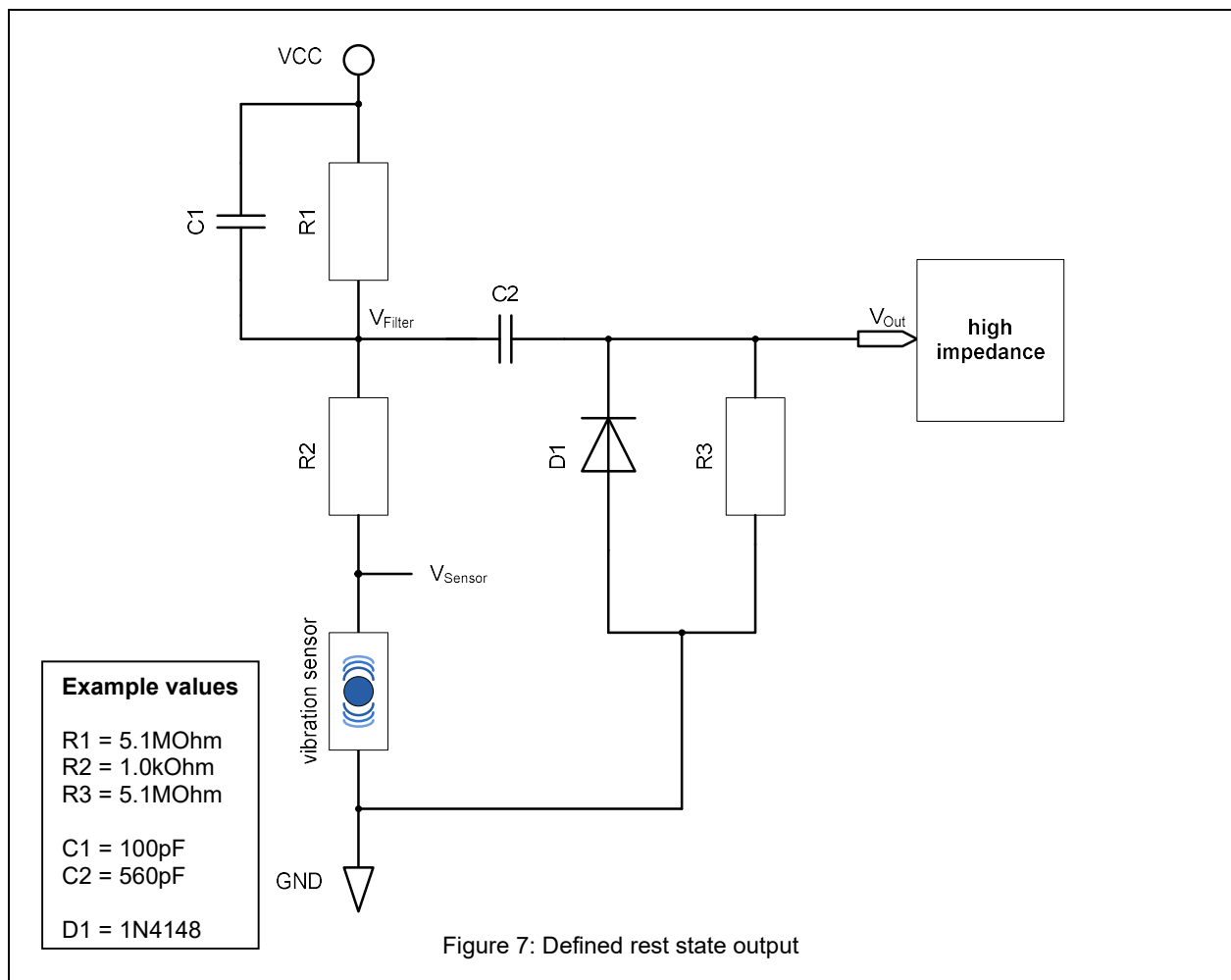

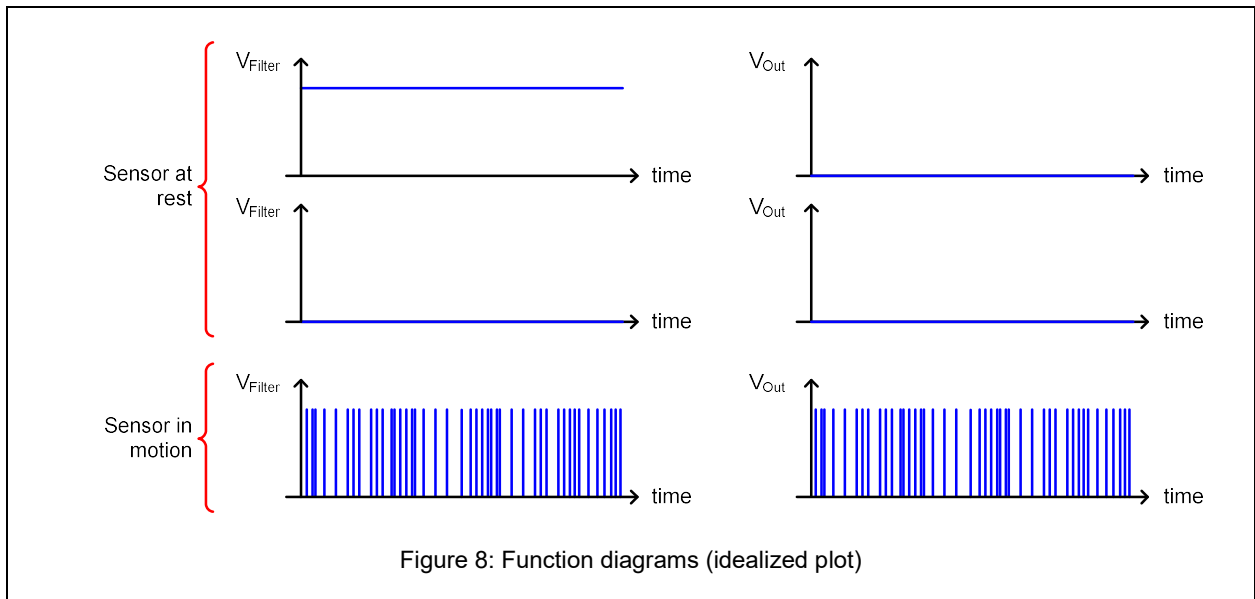

7. Delay circuit

7.1 General description

This circuit can be used, if the output signal needs to be **noise insensitive**, and **high** when the sensor is at rest (see Figure 10).

To increase the noise insensitivity, change the value of C2 in a range of 220nF – 4.7µF (for values $\geq 1\mu\text{F}$ use tantalum capacitors).

An increase of C2 increases the inactivity of the circuit. Therefore a longer excitation is required to reach the threshold voltages!

7.2 Circuit

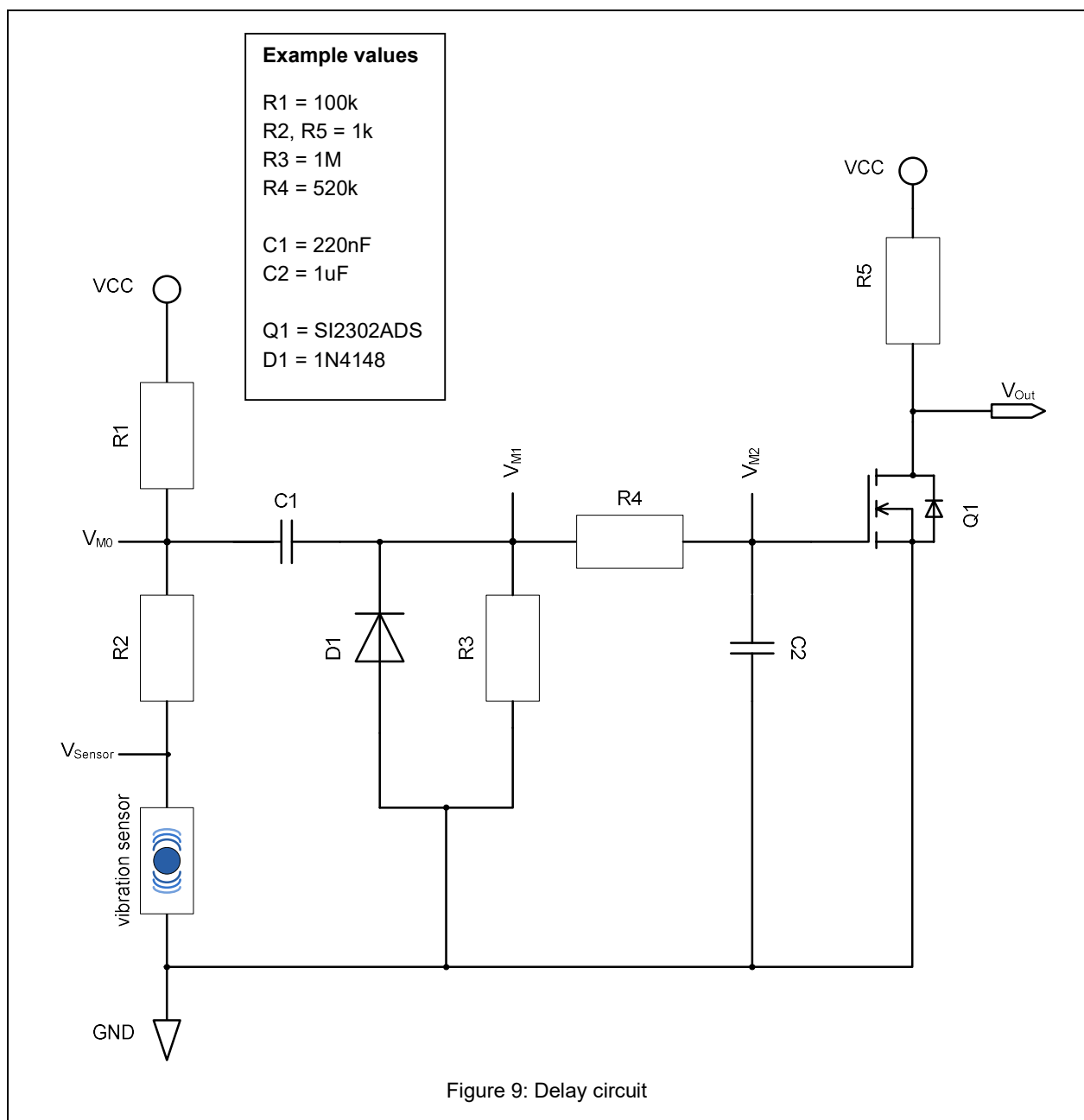

Figure 9: Delay circuit

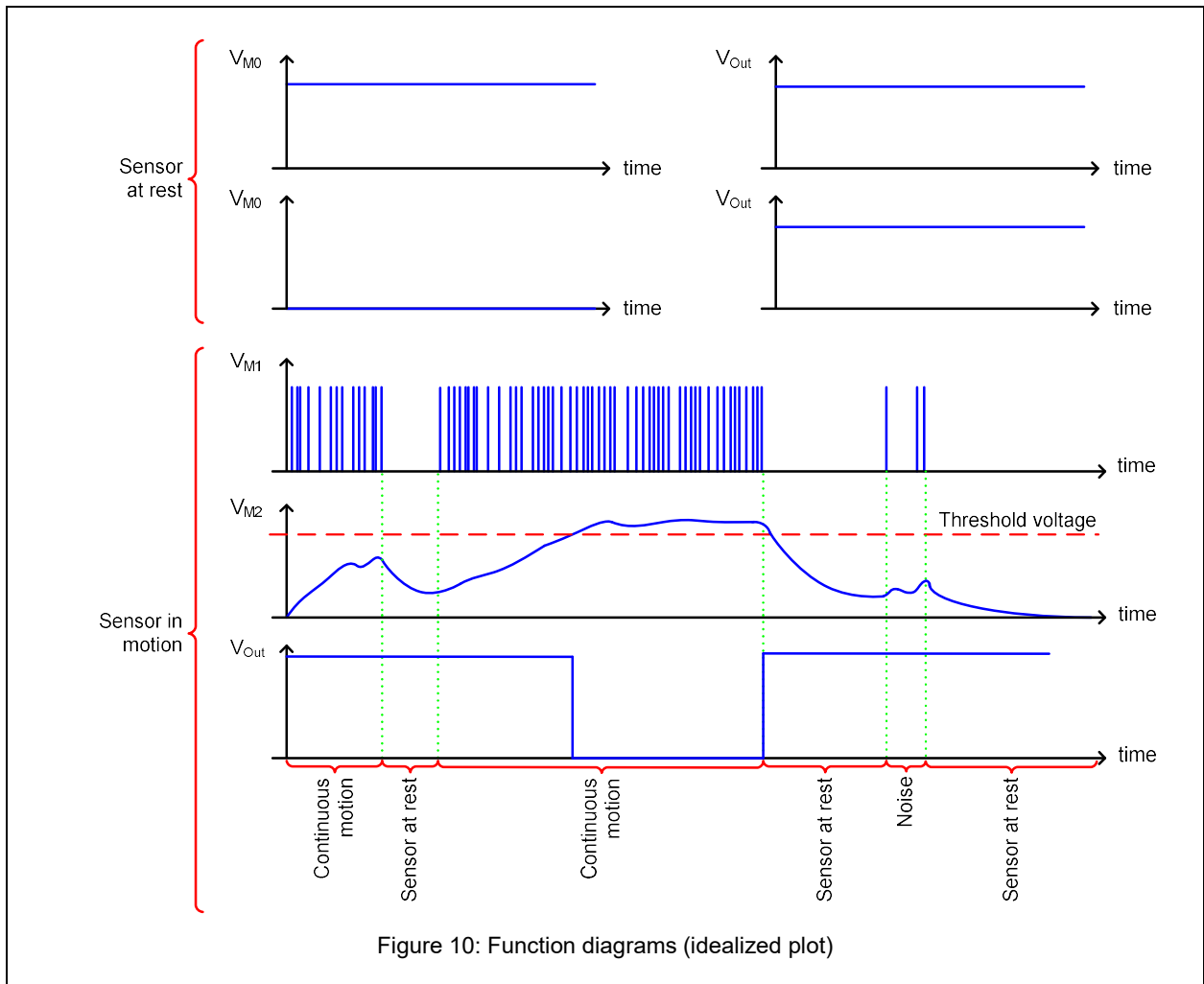

Figure 10: Function diagrams (idealized plot)

8. Digital filter

8.1 General description

The micro vibration sensor is connected to a low power micro controller to activate consumer electronics systems while in motion. When the device comes to rest, it is powered down (or up) by the microcontroller after a short delay time. The whole system is able to enter an idle mode with a current consumption of less than $0.6\mu\text{A}$, depending on the micro controller used.

The algorithms digitally filter the sensor signal and allow easy adjustment of triggering sensitivity of the sensor to the applications requirement. Furthermore the algorithms eliminate the effect of sensitivity differences from sensor to sensor that naturally occur.

8.2 Circuit

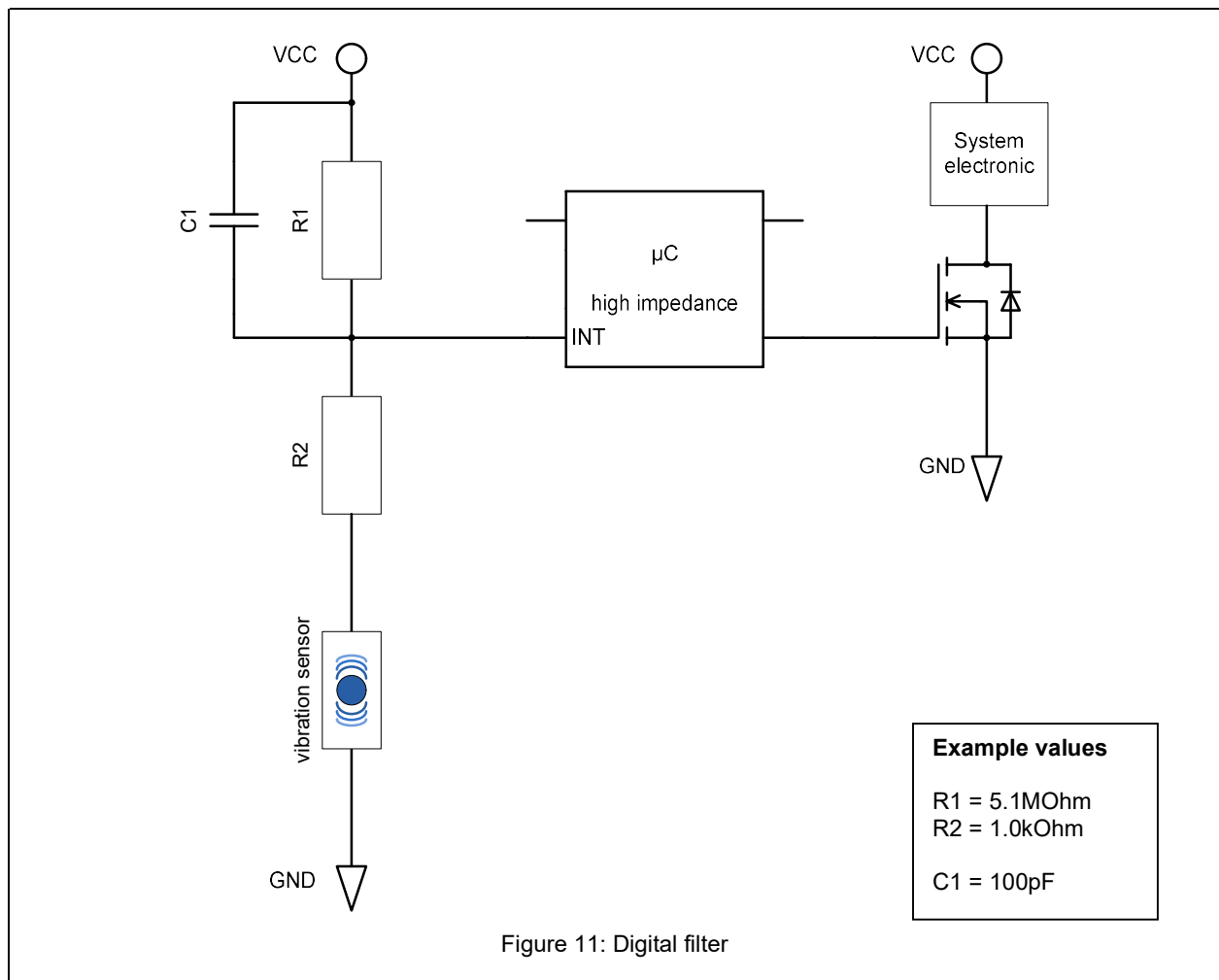

8.3 Schematic

The micro vibration sensor is connected in series with a 5.1 MOhm resistor, limiting the current running through the sensor. If the vibration sensor detects motion, a trigger signal is sent to the micro-controller and a timer delay will be started. Now it will be checked if there is a pulse in a time slot of e.g. 500ms. If there is no pulse the microcontroller is falling back into sleep mode after a short time. If there is a pulse after 500ms, check the following 500ms for a pulse etc. If threshold is reached, switch to a high power state or alarm. Vary the time and the amount of the time slots for different applications.

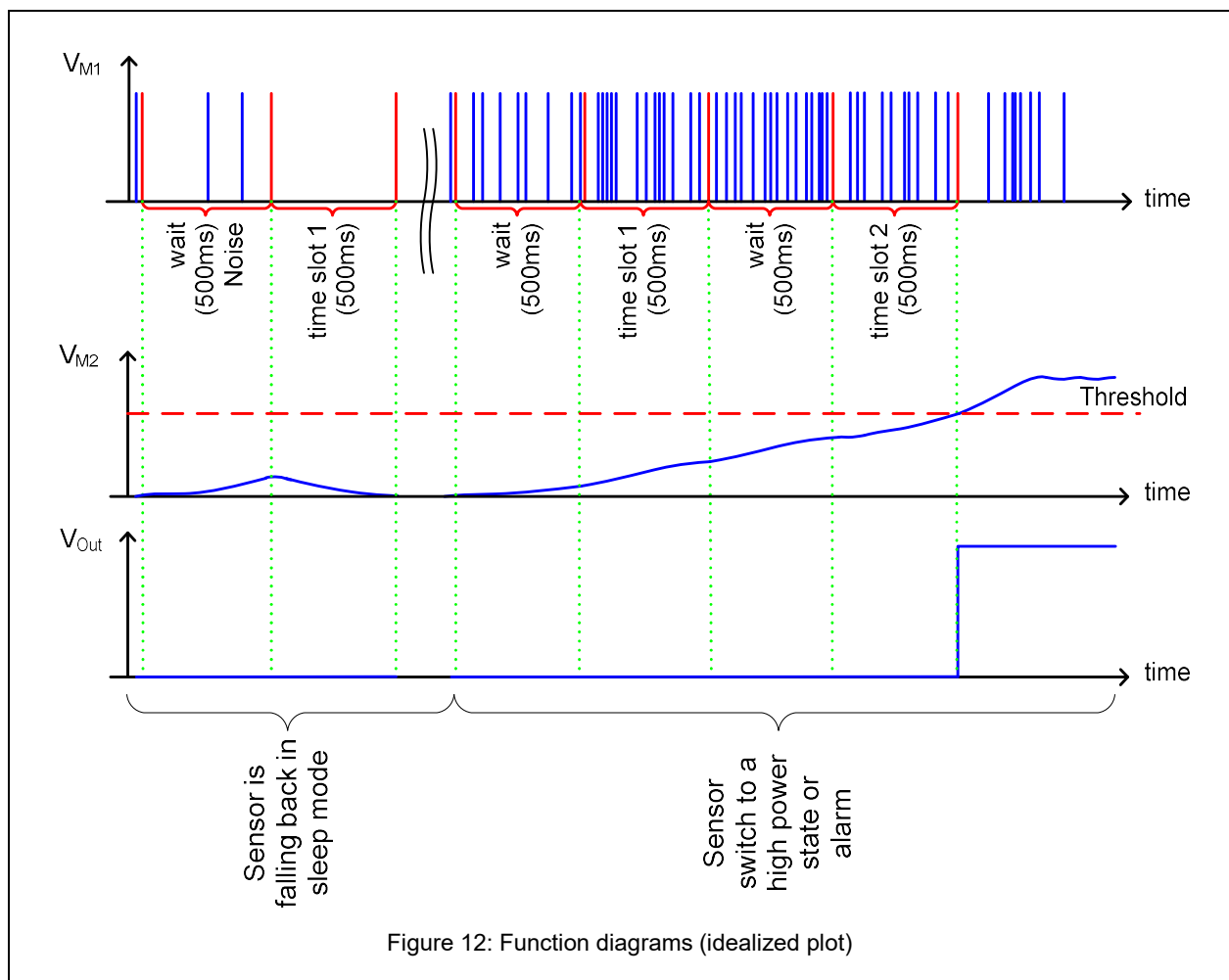

8.4 Implementation

- **Timer:** Generating a timer of e.g. 500ms.
- **Input:** Vibration sensor connected to an interrupt pin of the microcontroller to trigger an edge while in sleep mode.
- **On interrupt signal:** Disable further ext. interrupts.
- **On time slot:** Check for further pulse in a time slot of 500ms. If pulse detected, increment pulse counter variable by 3. Every 500ms, decrement pulse counter variable by 1 to decrease the value over time.
- **Theshold:** If the predefined pulse counter reach the threshold of 4 (4*500ms = 2 seconds of motion), switch to a high power state or alarm.

9. MOSFET Circuit

9.1 General description

To reduce the floating of the output please use the circuit below, by decoupling with a MOSFET, the situation is defused. Please note, when measuring with an oscilloscope, it is recommended to use the 10x probe for circuit debugging.

9.2 Circuit

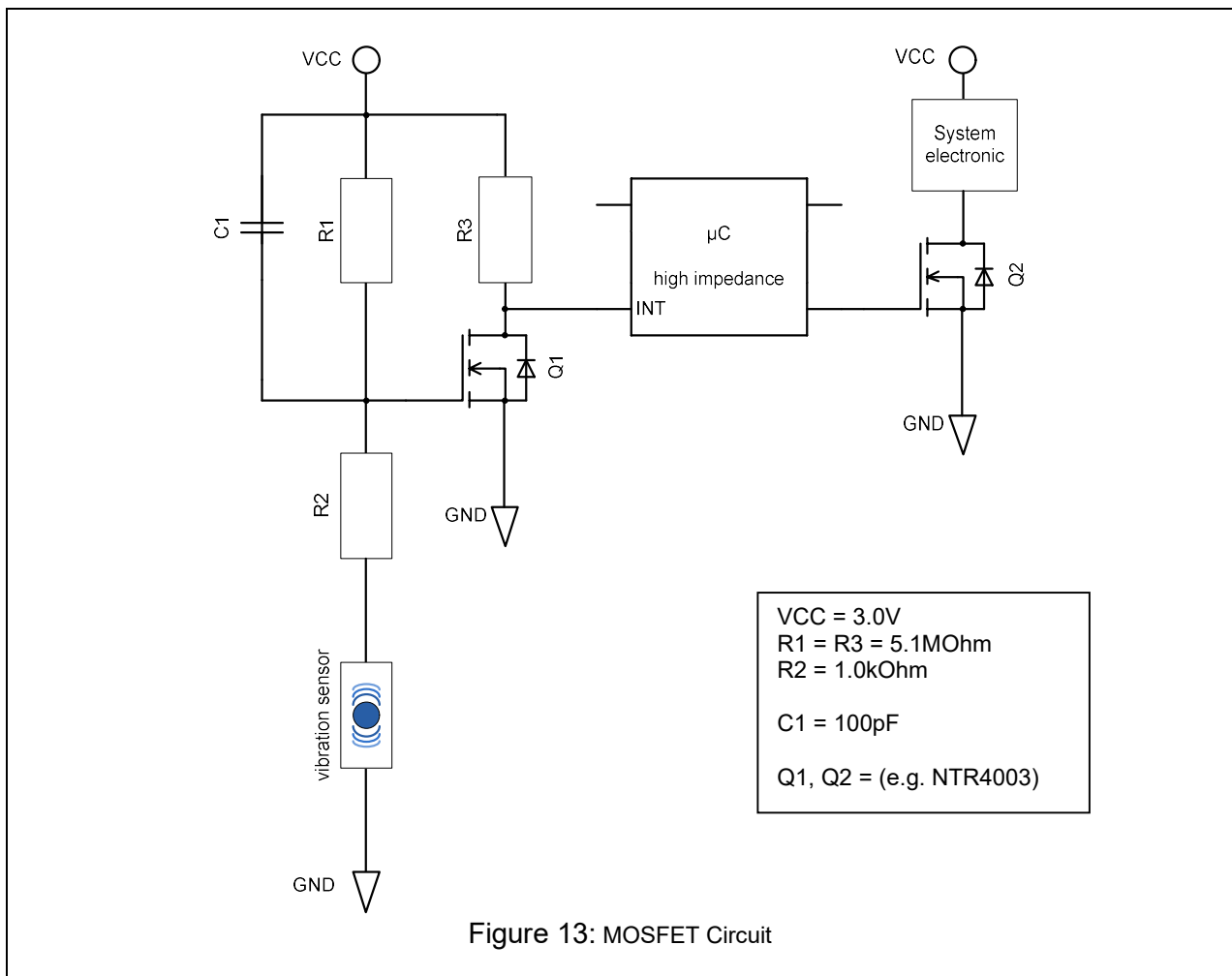

NOTES:

10. Important Notice

B&B Leiterplattenservice GmbH reserves the right to make corrections, modifications, enhancements, improvements, and other changes to its products and services at any time. Customers should obtain the latest relevant information before placing orders and should verify that such information is current and complete.

Information furnished by B&B Leiterplattenservice GmbH is believed to be accurate and reliable. However, this document may contain errors and omissions.

B&B Leiterplattenservice GmbH assumes no liability for applications assistance or customer product design. Customers are responsible for their products and applications using B&B Leiterplattenservice GmbH components. Accordingly, the design engineer should use this document as a reference rather than a strict design guideline and should perform thorough testing of any product that incorporates this or any other B&B Leiterplattenservice GmbH product.

B&B Leiterplattenservice GmbH products are not authorized for use in safety-critical applications (such as life support) where a failure of the sensors would reasonably be expected to cause severe personal injury or death, unless officers of the parties have executed an agreement specifically governing such use.

No license is granted by implication or otherwise under any patent or patent rights of B&B Leiterplattenservice GmbH. Trademarks and registered trademarks are the property of their respective companies.

On the following URL you can obtain information on other B&B Leiterplattenservice GmbH products and application solutions:

www.bb-gruppe.de

Mailing Address:

B&B Leiterplattenservice GmbH
Leipziger Strasse 40
09648 Mittweida, Germany